

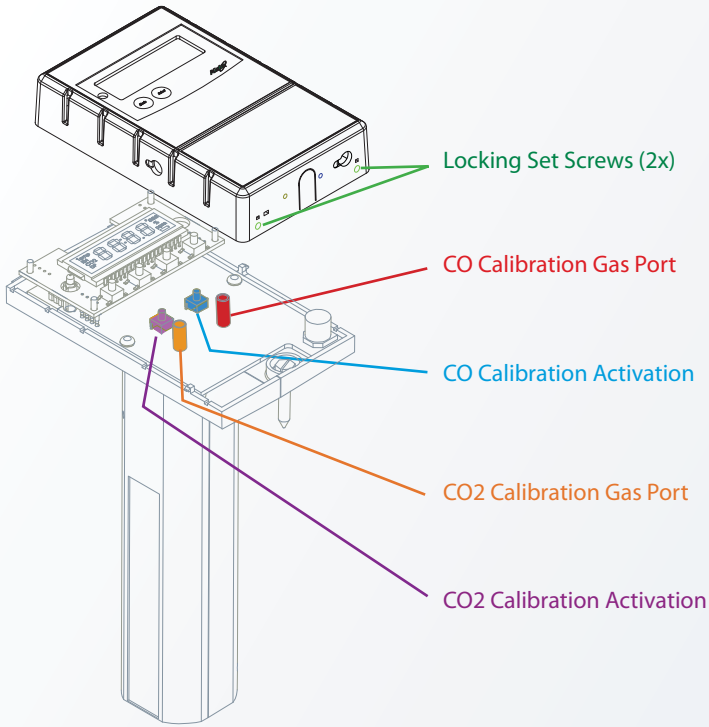

KTS Series Duct Mount Wiring and Calibration Instructions



Outputs available in either Voltage (0-10V) or Current (4-20mA)

Not all outputs are used on every unit. See product manual for output assignments.

All '-' terminals are electrically connected, but isolated from power supply.

KTS-134	
Output	Sensors
Output 1	CO
Output 2	RH
Output 3	VOC

KTS-213	
Output	Sensors
Output 1	CO2
Output 2	CO
Output 3	RH

KTS-234	
Output	Sensors
Output 1	CO2
Output 2	RH
Output 3	VOC

Power input
18-30 VDC
18-28 VAC
(polarity matters for VDC only)

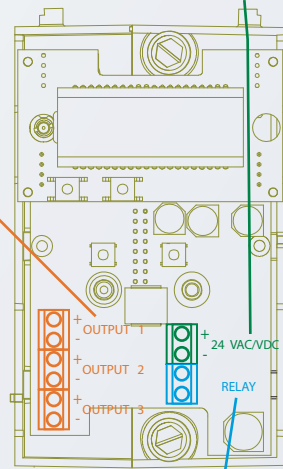

Relay is optional and may not be present (dry contact rated 24 VAC, 2A max)

Sensors	Threshold value
CO2	1000 ppm
CO	25 ppm
RH	Not rated
VOC	Alarm level

Voltage Output (0 - 10 VDC full scale)	Volts	CO2 ppm
	0 V	0 ppm
	5 V	1000 ppm
10 V	2000 ppm	

Current Output (4-20 mA full scale)	mA	CO2 ppm
	4mA	0 ppm
	12mA	1000 ppm
	20mA	2000 ppm

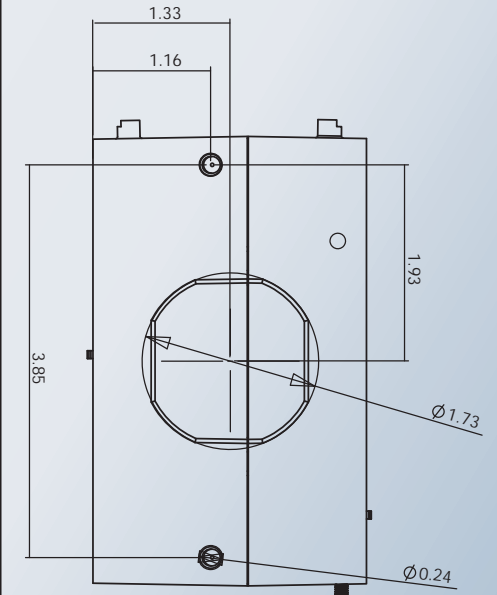

Duct Mounting Drill pattern
(Dimensions in inches)

Calibration Kit



Your sensor comes factory-calibrated and does not need to be calibrated upon initial installation. Calibration kits are available for both CO and CO2.

CO2 and CO Calibration Procedure

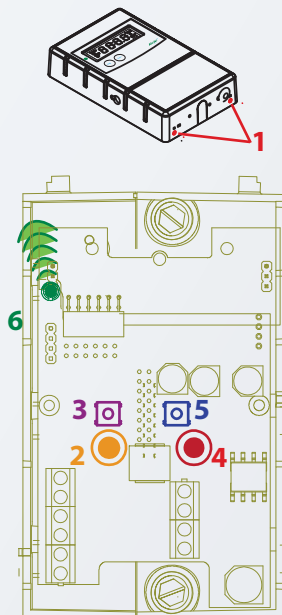

1. Back out set screws along bottom edge of enclosure cover and remove enclosure cover. Only one gas can be calibrated at a time following the procedures below:
2. For **CO2 calibration**, remove dust cover from left-most post. Connect 2000 PPM CO2 calibration gas. Turn on gas and allow to flow one minute before proceeding to step 3.
3. Press 'CO2 CAL' button for 5 seconds. LED will blink **yellow**. Proceed to step 6.
4. For **CO calibration**, remove dust cover from right-most post. Connect 25 ppm calibration gas. Turn on gas and allow to flow one minute before proceeding to step 5.
5. For **CO calibration**, press 'CO CAL' button for 5 seconds. LED will blink **yellow**.
6. After **5 minutes** the LED will **blink green**, indicating that the calibration process is completed.
7. Press and hold the applicable 'CO2 CAL' or 'CO CAL' button to accept calibration. The LED will turn **solid green** after only a few seconds.
8. At this point it is safe to turn off gas and remove gas tubing from calibration port.
9. When calibration is complete, replace dust cover(s) on gas calibration port(s).

Liquid Crystal Display (if equipped)

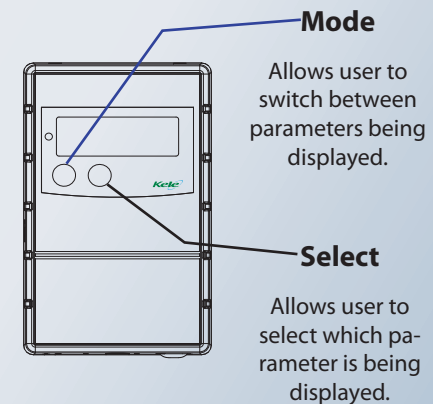

Align top and bottom latch and snap lid closed

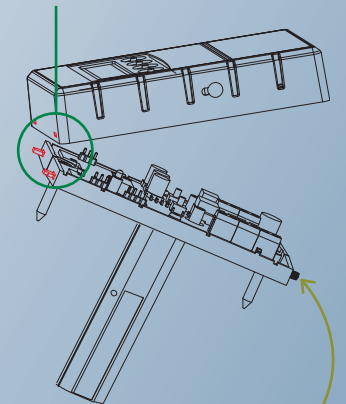

Once lid closed, insert set-screws to lock enclosure. Requires 1/16" Allen Wrench

Introduction

The KTS Series provides the ultimate in control of indoor air quality. Parameters sensed include:

1. Carbon Monoxide (CO)
2. Carbon Dioxide (CO₂)
3. Relative Humidity (RH)
4. Volatile Organic Compound (VOC)

A combination of any three of the above parameters may be sensed by the KTS Series:

KTS134 = CO/RH/VOC
 KTS213 = CO₂/CO/RH
 KTS234 = CO₂/RH/VOC

Each of the above can be configured for wall or duct-mounting. Options include a SPDT Relay and a Liquid Crystal Display (LCD).

Control outputs are available in Voltage (0-10V) or Current (4-20mA).

A simple one-point calibration procedure and a built-in calibration ports make the KTS simple to operate and maintain.

Displays and Indicators

The KTS Series includes a single tri-color LED on the front panel which illuminates whenever the unit is operating. This LED indicates:

- Green -> Normal level
- Yellow -> Warning level
- Red -> Alarm level

The LCD option adds 4 digit reporting to the front panel. The display shows the measured:

- CO concentration in parts per million (ppm)
- CO₂ concentration in parts per million (ppm)
- Relative Humidity in %

CARBON DIOXIDE SENSOR (CO ₂)	
Parameter	Value
Operating Principle	Non-dispersive infrared (NDIR)
Gas Sampling Method	Diffusion
Measurement Range	0-2000 ppm (Other ranges available by request)
Repeatability	± 20 ppm CO ₂
Measurement Accuracy	± 30 ppm ± 2% of reading
Recommended Calibration Interval	5 years
Warm Up Time	Less than 1 minute
Power Requirements	18 - 30 VDC or 18 - 28 Vrms AC
Operating Temperature Range	0 - 50 °C
Operating Humidity Range	0 - 99% RH, non-condensing
Voltage Output (linear)	0 - 10 VDC full-scale standard
Optional Current Output (linear)	4-20 mA R _{LOOP} < 600 Ω
Calibration	ONE Point : Single-button calibration (Patented)
Dimensions	4.5 x 2.8 x 0.9 inches

RELATIVE HUMIDITY SENSOR (RH)	
Parameter	Value
Operating Temperature	0 to 50 °C
Humidity Operating Range	0 to 99 % RH
Recovery time after 150 hours of condensation	10 Seconds
Humidity Hysteresis	± 1 % RH
Recommended Calibration Interval	Does not need calibration

VOLATILE ORGANIC COMPOUND SENSOR (VOC)	
Parameter	Value
VOCs detected	Alcohols, aldehydes, ketones, organic acids, amines, aliphatic and aromatic hydrocarbons
Typical response time	<1 minute to 90% full scale
Environmental temperature range	0 to 50 °C
Environmental humidity range	0 to 99% RH, non-condensing

CARBON MONOXIDE SENSOR (CO)		
Parameter	Value	Comments
Sensor type	Electrochemical	
Measurement range	0 – 200 ppm CO	
Accuracy	± 2.5% of full scale	0 – 50 °C
	± 4% of full scale	-30 – 0 °C
Recommended Calibration Interval	2 years	
Sensor Life	5 years typical	Actual life depends on ambient humidity & temperature. Replacement modules are available.
Power Consumption	.2 Arms	At 24 VAC
	1.1 Arms	At 24 VAC with heaters on
Status Indication	Tri-color status LED	Green -> Normal level Yellow -> Warning level Red -> Alarm level
Operating temperature	0 – 50 °C	
Storage temperature	-10 to 60 °C	
Relay outputs (R option only)	1 dry contact	Rated 24 VAC, 1A

Response to Carbon Monoxide

Current-loop output

The analog output always reflects the present sensor reading. The output is scaled so that 4 mA corresponds to a concentration of 0 ppm, and 20mA corresponds to the full scale reading of 200 ppm CO.

Concentrations above 200 ppm CO will always report 200 ppm.

A current-loop output below 4 mA indicates that the sensor reading is not available, either because the sensor failed or a calibration is in progress.

Warning/Alarm indications

Whenever the detected CO concentration is at or above 25 ppm, the 'STATUS' LED on the front cover turns yellow, and the relay actuates.

Whenever the detected CO concentration is at or above 50 ppm, the 'STATUS' LED on the front cover turns red. The 'WARNING' relay remains actuated while the 'ALARM' relay is actuated.

